

1.5m diameter 12 sided sump with reverse flange, corbel, adjustable height skirt, internal lid, and round 1020mm flat sealed cover and frame.

For reference purposes only. This drawing is not a specification. Order against product code only. To enable continuous improvement of our products, the designs and specifications are subject to change without notice.

FIBRELITE 
PART OF OPW A DOVER COMPANY

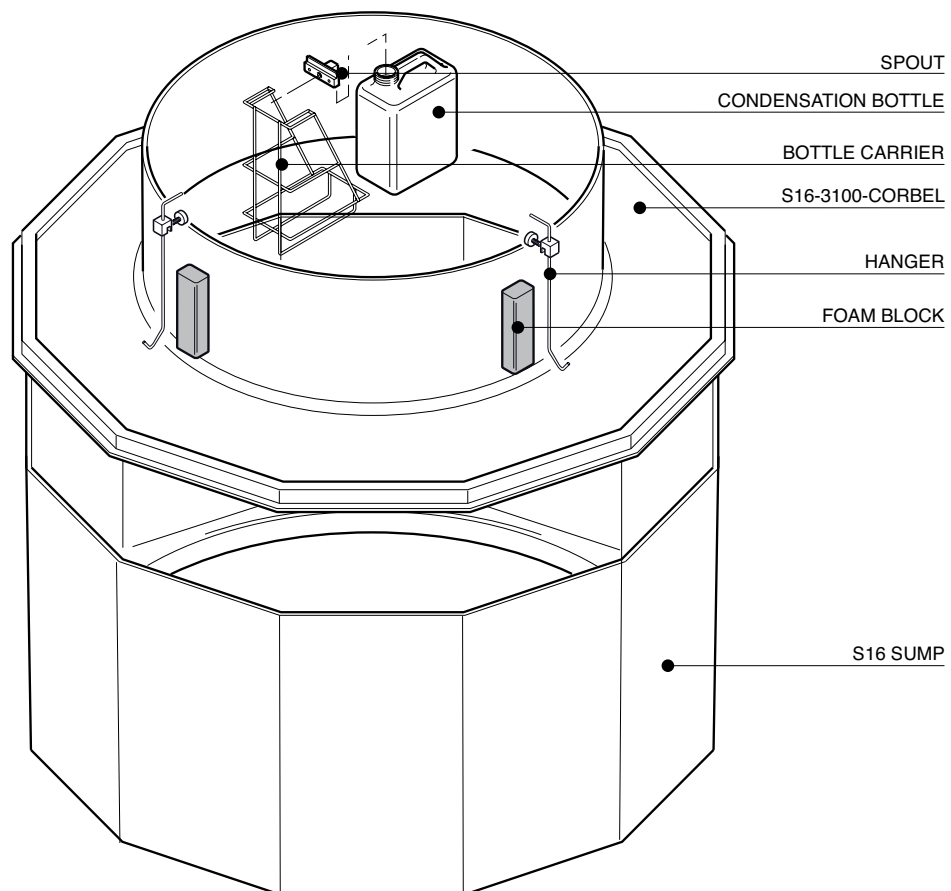
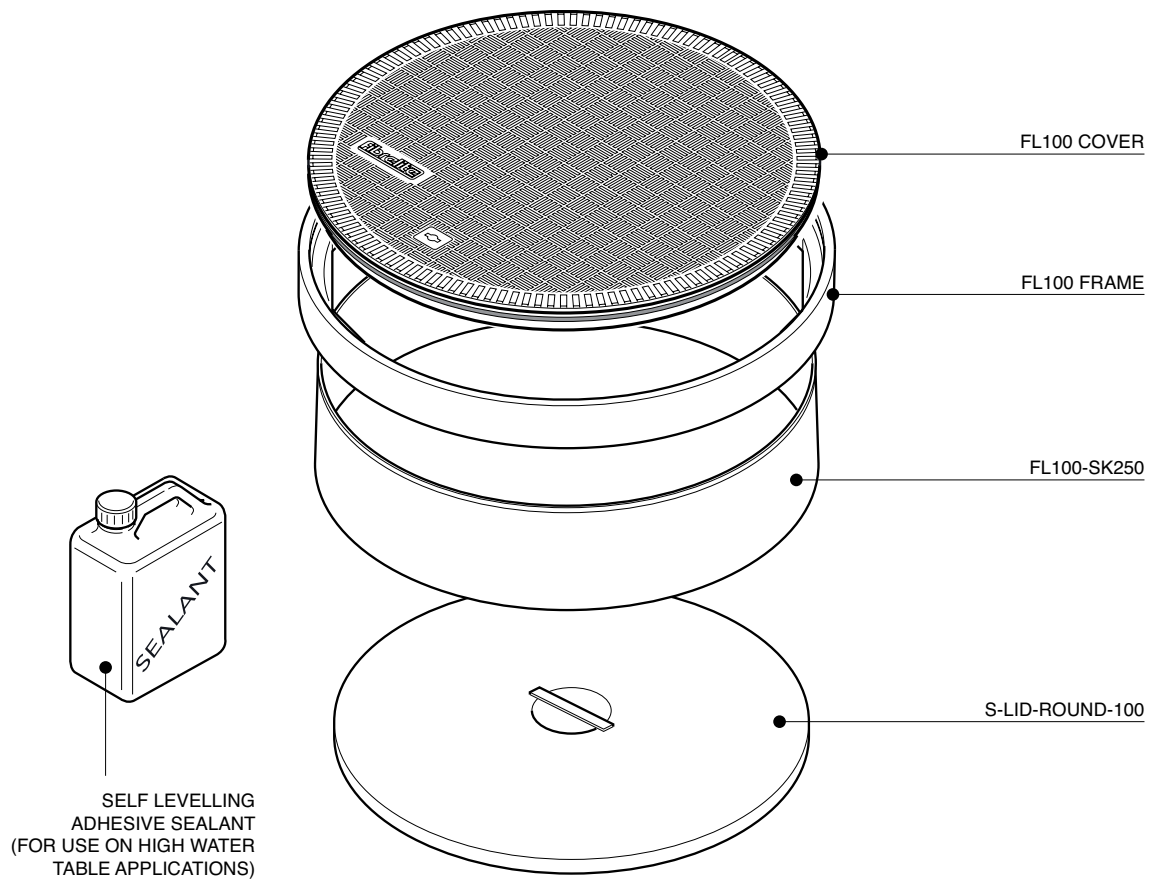

1.5m diameter 12 sided sump with reverse flange, corbel, adjustable height skirt, internal lid, and round 1020mm flat sealed cover and frame.

For reference purposes only. This drawing is not a specification. Order against product code only. To enable continuous improvement of our products, the designs and specifications are subject to change without notice.

FIBRELITE 
PART OF OPW A DOWDER COMPANY

24 No. Ø13 HOLES
ON 1330 PCD

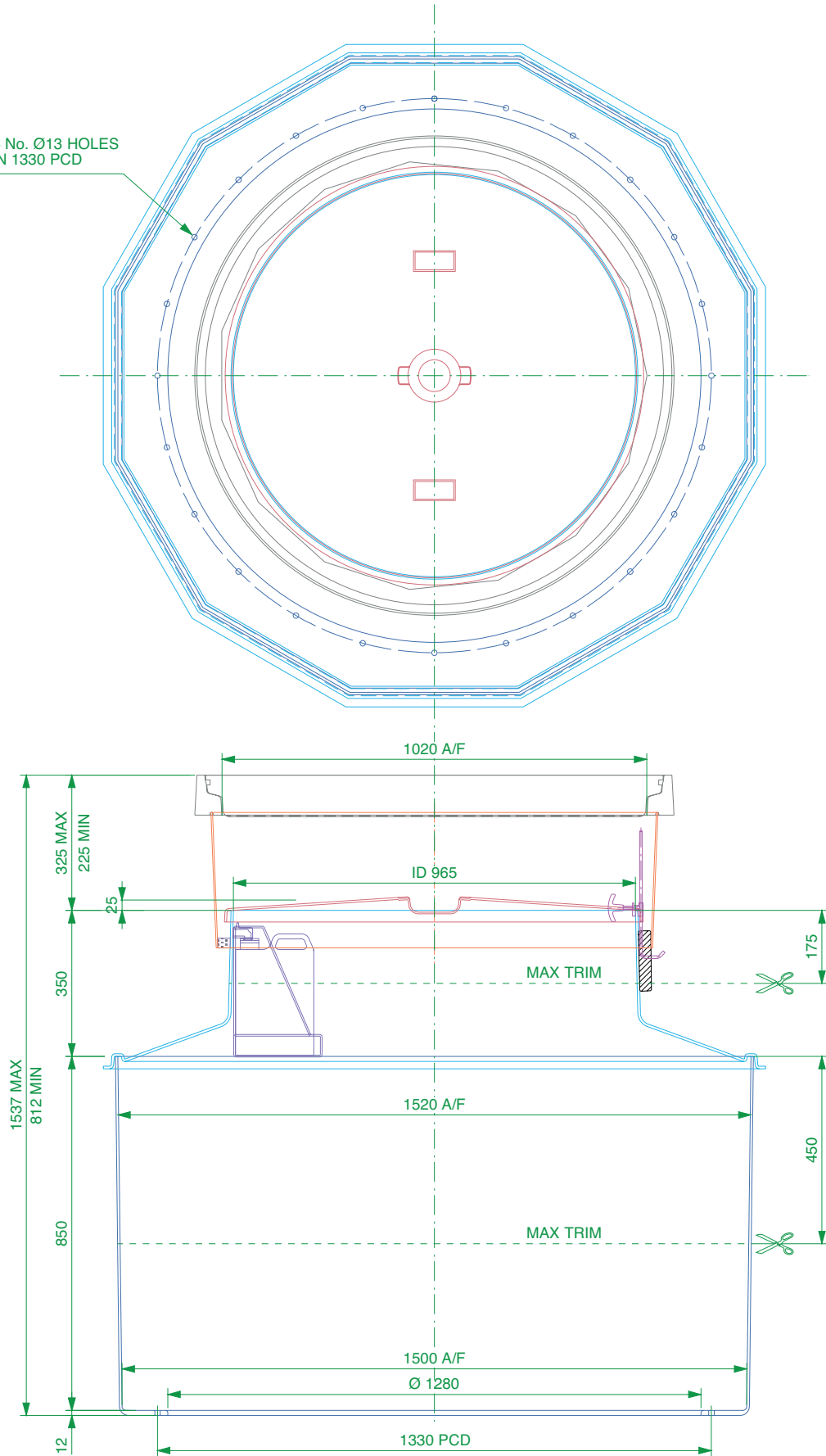

1.5m diameter 12 sided sump with reverse flange, corbel, adjustable height skirt, internal lid, and round 1020mm flat sealed cover and frame.

For reference purposes only. This drawing is not a specification. Order against product code only. To enable continuous improvement of our products, the designs and specifications are subject to change without notice.

FIBRELITE 
PART OF OPW A DOVER COMPANY

! VERY IMPORTANT !
 OUTER EDGE "A" OF FRAME SET 5 - 10MM
 ABOVE GENERAL FORECOURT AREA WITH
 CONCRETE RAMPED AWAY OVER 300MM.

TYPICAL INSTALLATION

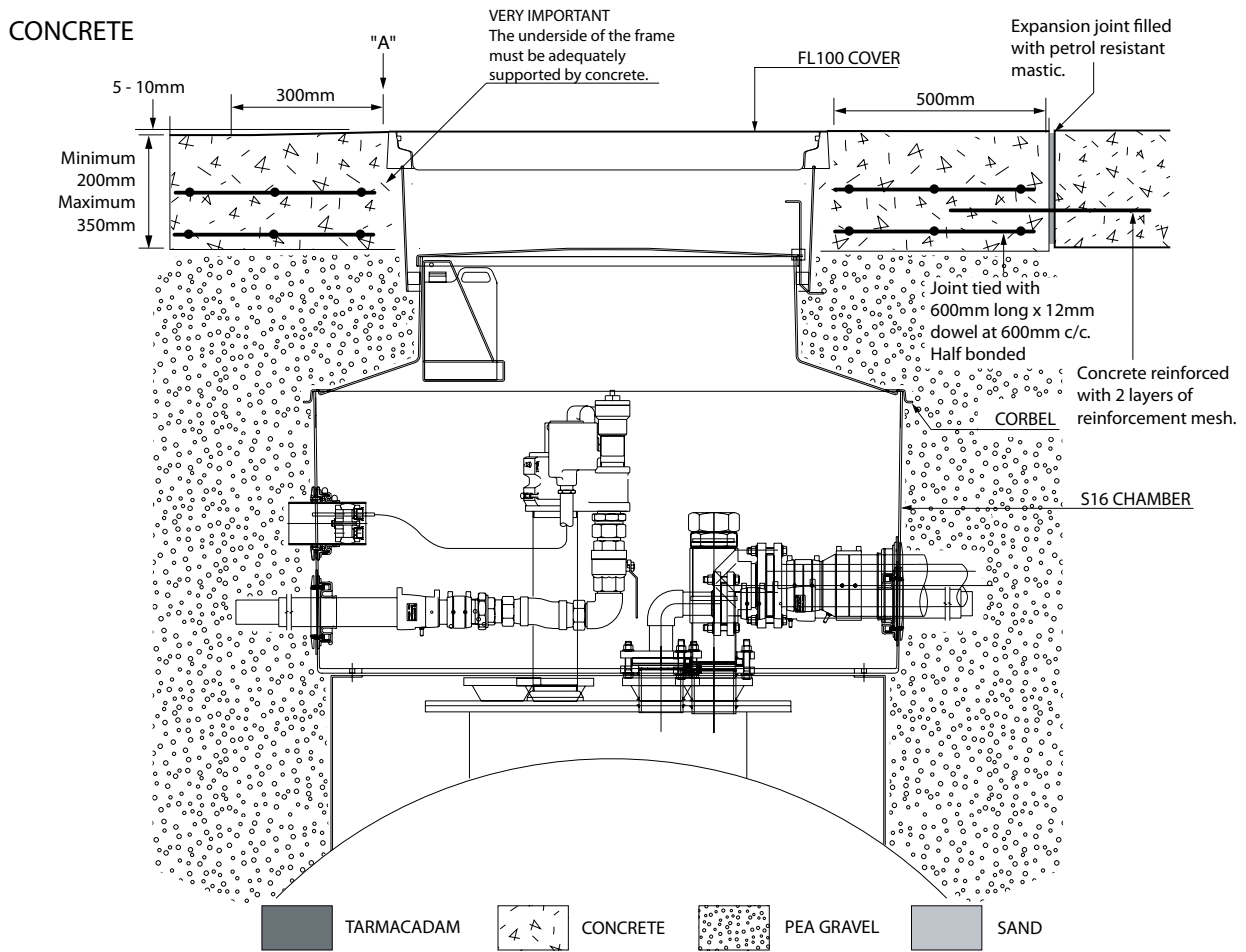

ALTERNATIVE INSTALLATION ADVICE

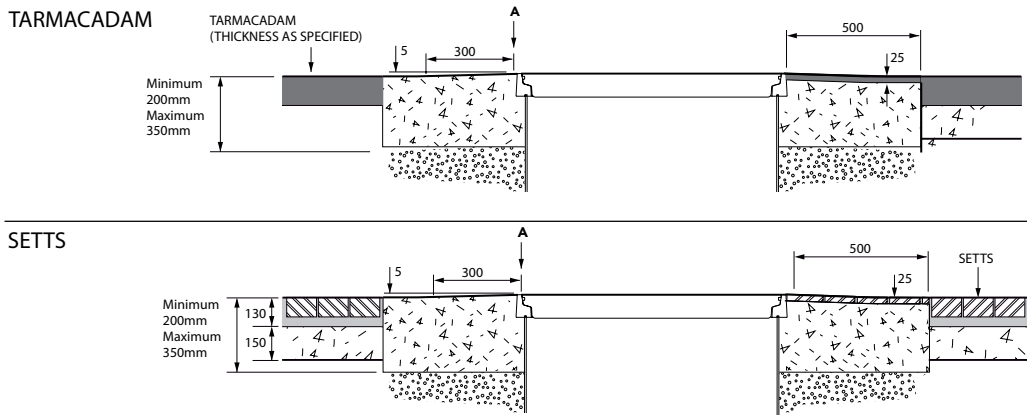

1.5m diameter 12 sided sump with reverse flange, corbel, adjustable height skirt, internal lid, and round 1020mm flat sealed cover and frame.

For reference purposes only. This drawing is not a specification. Order against product code only. To enable continuous improvement of our products, the designs and specifications are subject to change without notice.

FIBRELITE 
 PART OF OPW A DOVER COMPANY