

Materials

Body: Cast aluminum

Main Stem: Stainless steel

Stem Seal: Buna-N O-Ring

Disc: Viton®

Spout: Aluminum

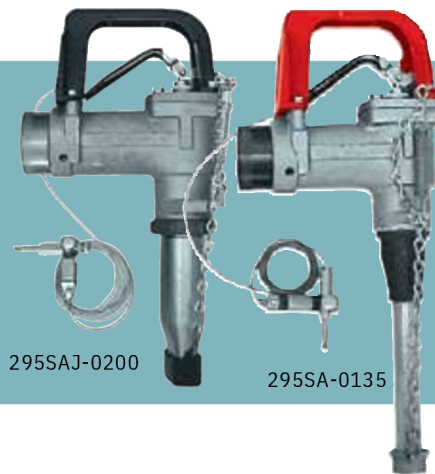

295SAJ-0200

295SA-0135

Features

- ◆ Aluminum Body – lighter weight, easier to maneuver.
- ◆ Dual Poppets – easy-to-open nozzle against high inlet pressures.
- ◆ Color-Coded Composite Lever Guards – helps distinguish between AVGAS and Jet A. Easily replaced in lever guard kit.
- ◆ Right Angle Design – provides larger lever area for better grip and easier control.
- ◆ Vinyl-Coated Lever – insulates fingers against cold.
- ◆ 100 Mesh Strainer – prevents foreign matter from entering fuel tank; easy to remove and clean.
- ◆ Dust Cap – keeps spout free from dirt and stops fuel drippage when connected.
- ◆ Adjustable Dash Pot – permits adjusting the main poppet closure rate over a wide range of flows to overcome line shock with minimum afterflow.
- ◆ Easily replaced spout – the spout is easily threaded into the body. Replacement spouts are readily available from OPW.
- ◆ Built-In Swivel – eliminates twisting and kinking of the hose. This swivel is electroless nickel-plated and has full-bearing surfaces.
- ◆ NPT Female Threads at Inlet End of 295SA – accepts all 1", 1-1/4" or 1-1/2" male connections.
- ◆ NPT Female Threads At Inlet End of 295SAJ – accepts all 1-1/2" male connections.
- ◆ Unique Jet Aircraft Spout Design of 295SAJ – to help prevent inadvertent fueling of piston engine aircraft with turbine fuel.
- ◆ Ground Wire Assembly – included on all aviation nozzles.

Design working pressure

- ◆ 110 psi (7.58 bar) maximum pressure

Level Guard Replacement Kits

Product #	Nozzle
295KLG-0300	295SA-0135, 0136, 0137, 295SAC-0156, 0157 Red
295KLG-0350	295SA-0138, 275SAC-0158 Red
295KLG-0400	295SAJ-0200, 295SACJ-0200 Black

All lever guard kits include new lever sub-assembly.
295 Series Instruction Sheet Order Number: **H09237PA**

Overwing Aircraft Nozzles

295SA – AVGAS 295SAJ – Jet

Fuel

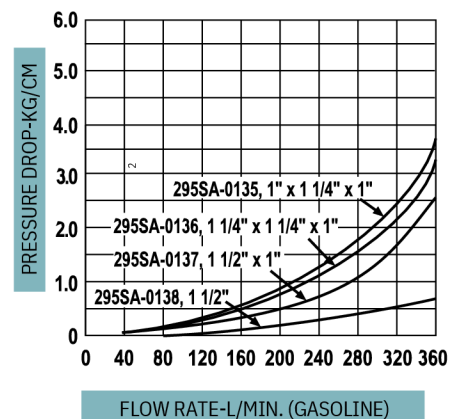
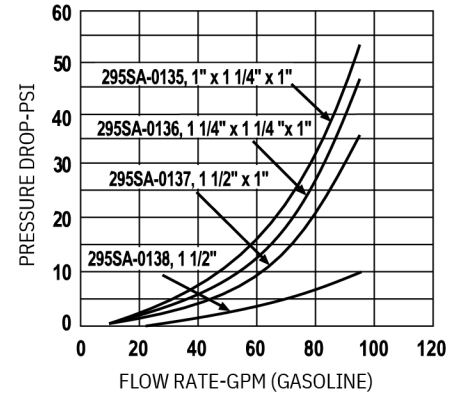

Ordering Specifications

Product #	Inlet Thread		Spout O.D			
	in.	mm	lbs.	kg	in.	mm
295SA-0135	1	25	4.60	2.10	1	25
295SA-0136	1 1/4	32	4.50	2.00	1	25
295SA-0137	1 1/2	38	4.50	2.00	1	25
295SA-0138	1 1/2	38	5.10	2.30	1 5/8	41
295SAJ-0200	1 1/2	38	5.60	2.50	2 3/8	54
295SAC-0156*	1 1/4	32	4.50	2.00	1	25
295SAC-0157*	1 1/2	38	4.50	2.00	1	25
295SAC-0158*	1 1/2	38	5.15	2.30	1 5/8	41
295SACJ-0200*	1 1/2	38	5.65	2.60	2 3/8	54

*Check Valve

Replacement Parts - OPW 295SA/295SAC & 295SAJ

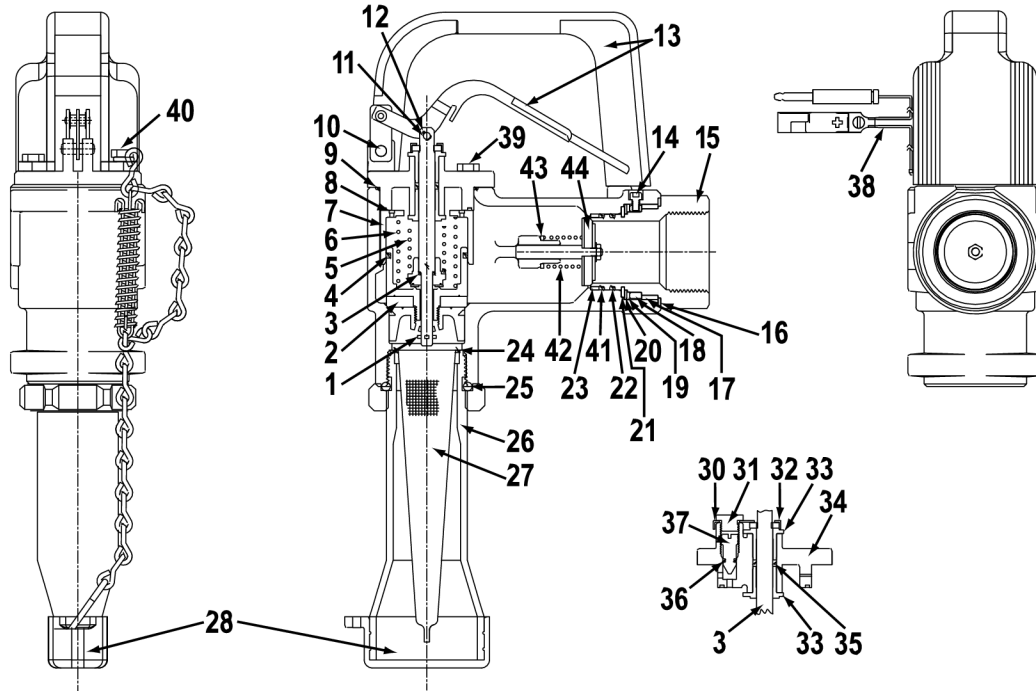

Key	Part #	Description	295SA-0135 inlet/ spout 1" x 1"	295SA-0136 & 295SAC-0156 inlet/ spout 1½" x 1"	295SA-0137 & 295SAC-0157 inlet/ spout 1½" x 1"	295SA-0138 & 295SAC-0158 inlet 1½"/" x 1½"	295SAJ-0200 & 295SACJ-0200 inlet/ spout 1½"/1½"
12	H02477M	Cotter Pin
33	H07719	Main Poppet S/A
4	H09420	Stem & Sec. Poppet
5	H09417	Stem & Sec. Poppet
6	H12706M	O-Ring
7	H09367M	Spring
8	H05064M	Spring
9	H05088M	Skirt
10	H05198M	Seal
11	H04828M	Seal
12	H03981RE	Pin
13	H05000M	Cotter Pin
13	H07580M	Rivet
13	295KLG-0300	Lever Guard Kit*
14	295KLG-0350	Lever Guard Kit*
15	295KLG-0400	Lever Guard Kit*
15	H13774M	Screw (3 req'd)*
15	295SWK-0007	Swivel Repair Kit**
15	295SWK-0009	Swivel Repair Kit**
16	295SWK-0014	Swivel Repair Kit**
16	295SWK-0013	Swivel Repair Kit**
17	H08886M	Dust Seal
17	H01227M	Dust Seal
18	H08887M	Bearing
18	H08879M	Bearing
	H09713RS	Retainer
	H09712RS	Retainer

* Replacement part for nozzles built after 08/1998. Part is unavailable for nozzles built before this date.

** Includes 295SRK-0001 or 295SRK-0002 and contact ring.

Replacement Parts-OPW 295SA/SAC & SAJ Aircraft Nozzles

Key	Part #	Description	295SA-0135 inlet/ spout 1" x 1"	295SA-0136 & 295SAC- 0156 inlet/spout 1 1/4" x 1"	295SA-0137 & 295SAC- 0157 inlet/spout 1 1/2" x 1"	295SA-0138 & 295SAC- 0158 inlet/spout 1 1/2" x 1 1/2"	295SAJ-0200 & 295SACJ-0200 inlet/ spout 1 1/2" x 1 1/2" /2"
19	H08881M	Thrust Bearing	.	.	.		
19	H08889M	Thrust Bearing				.	.
20	H08882M	Lock RIng	.	.	.		
20	H08890M	Lock RIng				.	.
21	H09365M	Retaining Ring	.	.	.		
21	H09366M	Retaining Ring				.	.
22	H12319M	O-Ring, Buna-N	.	.	.		
22	H12320M	O-Ring, Buna-N				.	.
23	H08884M	Bearing	.	.	.		
23	H08892M	Bearing				.	.
24	H06026M	O-Ring	.	.	.		
24	H07670M	O-Ring				.	
24	H11499M	O-Ring					.
25	H05297M	O-Ring	.	.	.		
25	H07766M	O-Ring				.	
25	H10458M	O-Ring					.
26	297SA-9050	Spout S/A	.	.	.		
26	297SA-9060	Spout S/A				.	
26	696J-7010	Spout S/A					.
27	190S-7063	Strainer	.	.	.		
27	153-0910	Strainer				.	
27	153J-0100	Strainer					.
28	H10387	Cap & Chain S/A	.	.	.		
28	H10388	Cap & Chain S/A				.	
28	296CJ-0100	Cap & Chain S/A					.
29	H09212	Body Cap S/A**	.	.	.		
29	H09213	Body Cap S/A**				.	.
30	H05135M	Retainer
31	H08441RS	Screw
32	H05087M	Felt Wiper
33	H05063M	Bushing
34	C02115A	Cap	.	.	.		
34	C02117A	Cap				.	.
35	H12707M	O-Ring
36	H12705M	O-Ring
37	H04825M	Adj. Screw
38	190WM-8001	Ground Wire S/A
39	H07062M	Screw (4 req'd)
40	H06045M	Screws (2 req'd)
41	H13776M	O-Ring, Viton®				.	.
41	H13775M	O-Ring, Viton®	.	.	.		

** Body Cap sub-assembly includes parts 30-37.

Replacement Parts - OPW 295SAC & 295SACJ Only

Key	Part #	Description	295SAC-0156	295SAC-0157	295SAC-0158	295SACJ-0200
42	H07595M	Spring SST	.	.		
42	H07593M	Spring SST			.	.
43	H07613M	Washer, nylon
44	H09214	Poppet S/A	.	.		
44	H09215	Poppet S/A			.	.