

FL100

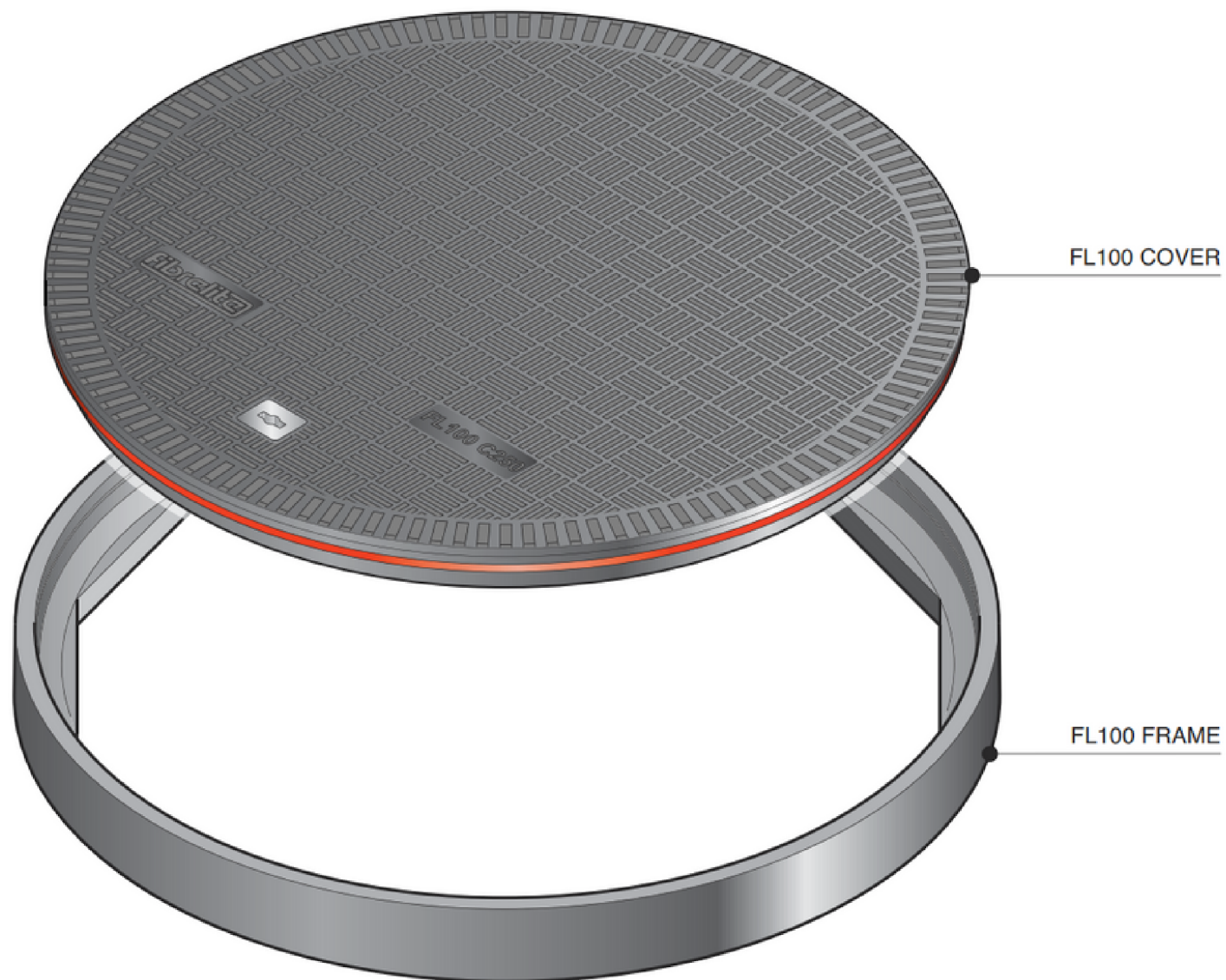

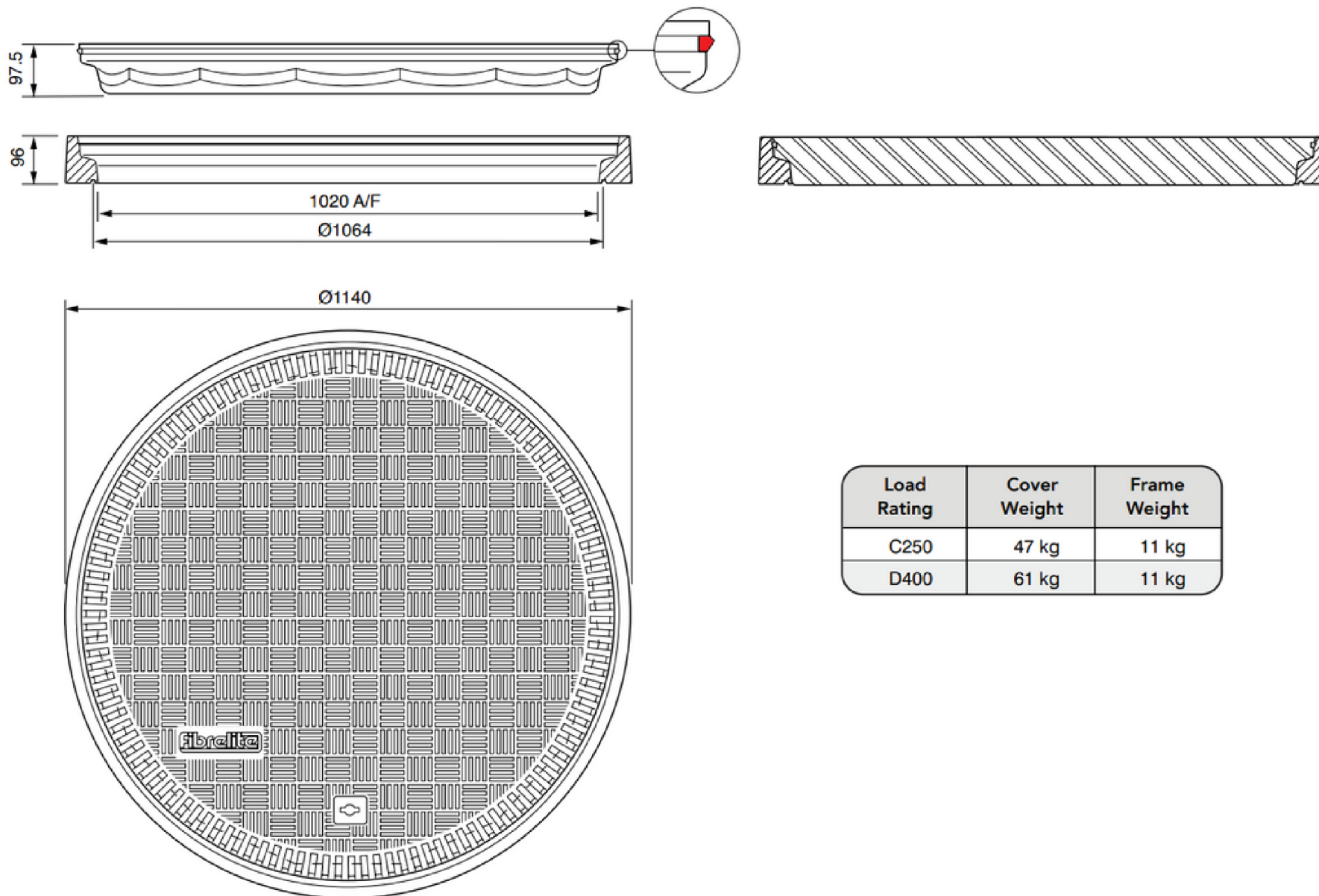

CONCRETE

VERY IMPORTANT

OUTER EDGE "A" OF FRAME SET 5MM ABOVE GENERAL FORECOURT AREA WITH CONCRETE RAMPED AWAY OVER 300MM

VERY IMPORTANT

The underside of the frame must be adequately supported by concrete.

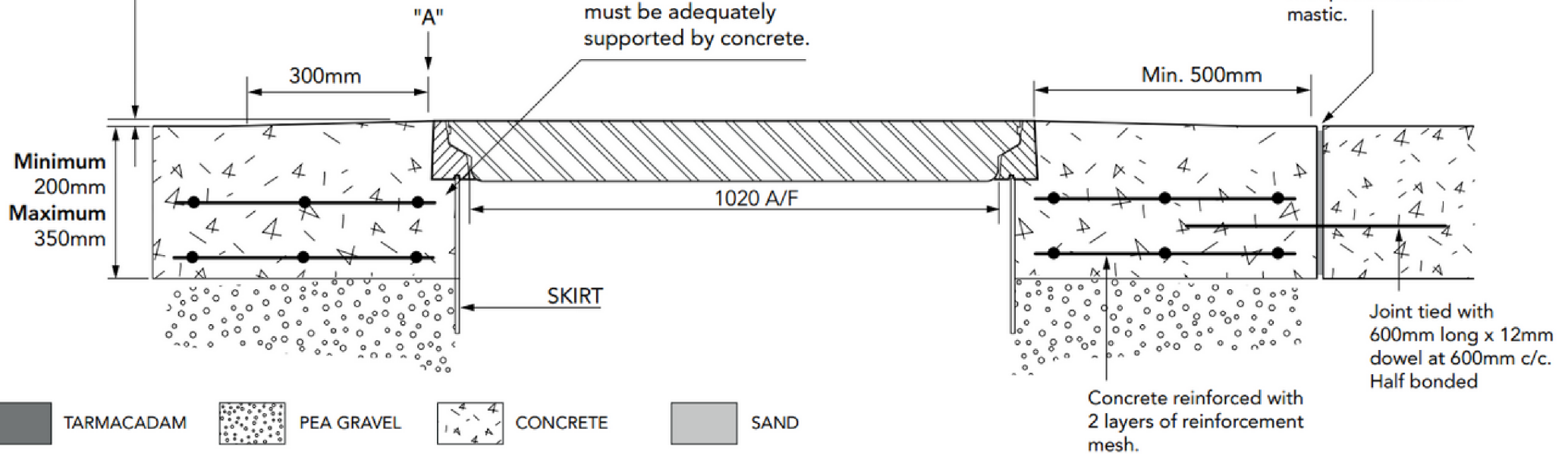

TARMACADAM

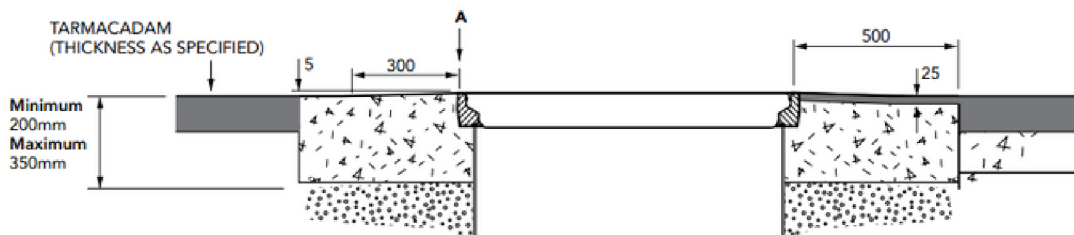

SETTS

